

SPECIFICATIONS

MATERIAL

Table and Seat Tops: 1 1/2" x 3 1/2" recycled plastic slats.

Frames: Basic frame - for table: 3" x 3" x 3/16" angle welded to 3" x 3" x .120 wall tube; for seats: 3" x 3" x 3/16" angle welded to 3" x 3" x .120 wall steel tube; table center brace 1 1/2" x 1 1/2" x .120 wall steel tube; table top slats supported by a complete framework. All steel drilled and formed for quick assembly. All steel shall conform to ASTM A36 hot rolled steel.

HARDWARE

Recycled plastic slats shall be attached to frames with 3/8" plated carriage bolts, nuts and washers.

SURFACE MOUNTING:

Anchor bolts by others

PERMANENT EMBED MOUNTING:

Depth and diameter of post hole may vary with soil conditions. Consult project engineer for correct dimensions. **Rebar by others**

PROTECTIVE COATINGS Following fabrication frames shall be cleaned and treated with an iron phosphate process prior to the coating application. This process shall include a non-chromated alkaline cleaner, and an iron phosphate treatment followed with an acidic sealer for maximum adhesion. The protective coatings shall be either polyester or polyester TGIC powder. Following application the parts shall be baked until properly cured. The coating shall be a minimum of 4 mils thick on all surfaces.

OPTIONS

Mounting: surface mount or permanent embed

Table & Seat Tops:

Recycled Plastic: Gray,
weathered wood, cedar

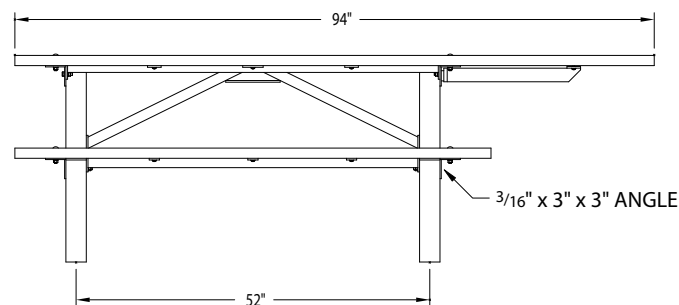
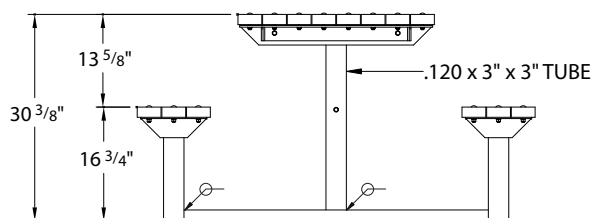
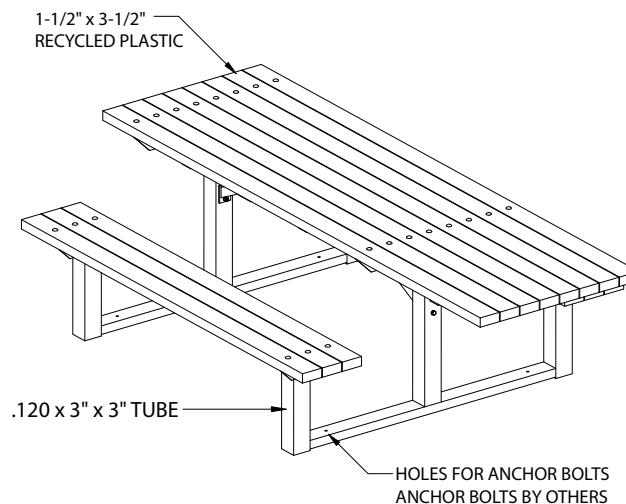
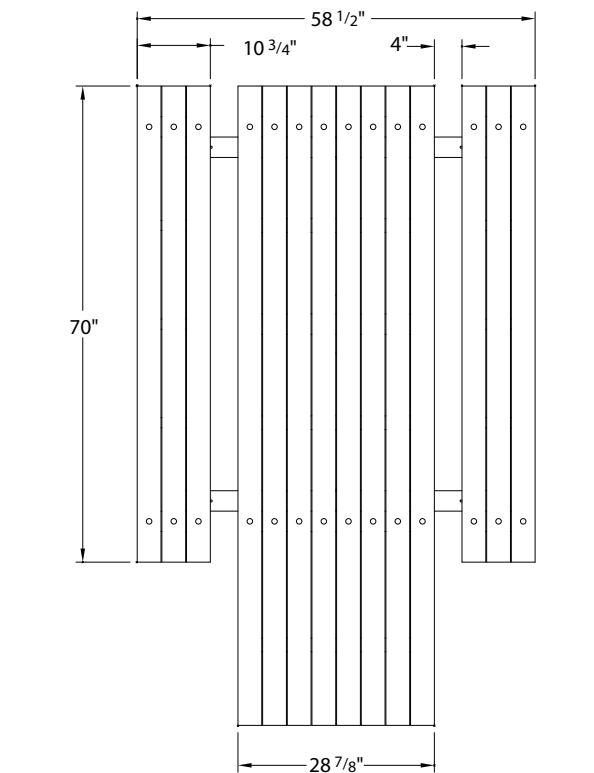

REV 9-22-06

Model F-5P Picnic Table, 6 ft. ADA Recycled Plastic, Surface Mount

FairWeather Site Furnishings

360-895-2626 or Toll Free 800-323-1798

Port Orchard, Washington

©1999-2006 Leader International Corporation,
FairWeather Site Furnishings division