

## SPECIFICATIONS

### MATERIAL

The TR-3 trash receptacle shall be fabricated with 1/4 x 2" mild steel vertical slats welded to 1/4 x 2" hoops. Decorative rings, shall be 3" sch. 80 pipe, 3 1/2" OD, 1/2" thick, welded to hoops. All steel shall conform to ASTM A36 hot rolled steel and shall be wheelabrated prior to fabrication. Hinged flat top is 3/16" mild steel attached with SS continuous hinge.

Liner shall be 30 gallon galvanized metal can powder coated to match the receptacle.

Optional dome top shall be 16 gauge spun steel powder coated to match the receptacle.

Ash pan shall be stainless steel powder coated to match the receptacle.

### WELDS

All welds between flat straps shall be smooth, continuous fillet welds ground smooth where necessary, to remove any burrs or sharp edges. All rings shall be welded to the horizontal bands and ground smooth. Spot welds at this juncture are not acceptable.

### PROTECTIVE COATINGS

Following fabrication the receptacles shall be cleaned and treated with an iron phosphate process prior to the coating application. This process shall include a non-chromated alkaline cleaner and an iron phosphate treatment followed with an acidic sealer for maximum adhesion. The protective coating shall be either polyester or polyester TGIC powder applied by the dry electrostatic method. The resultant coating shall be minimum of 4 mills thick on all surfaces.

### OPTIONS

35 Gallon Liner  
Leveling legs

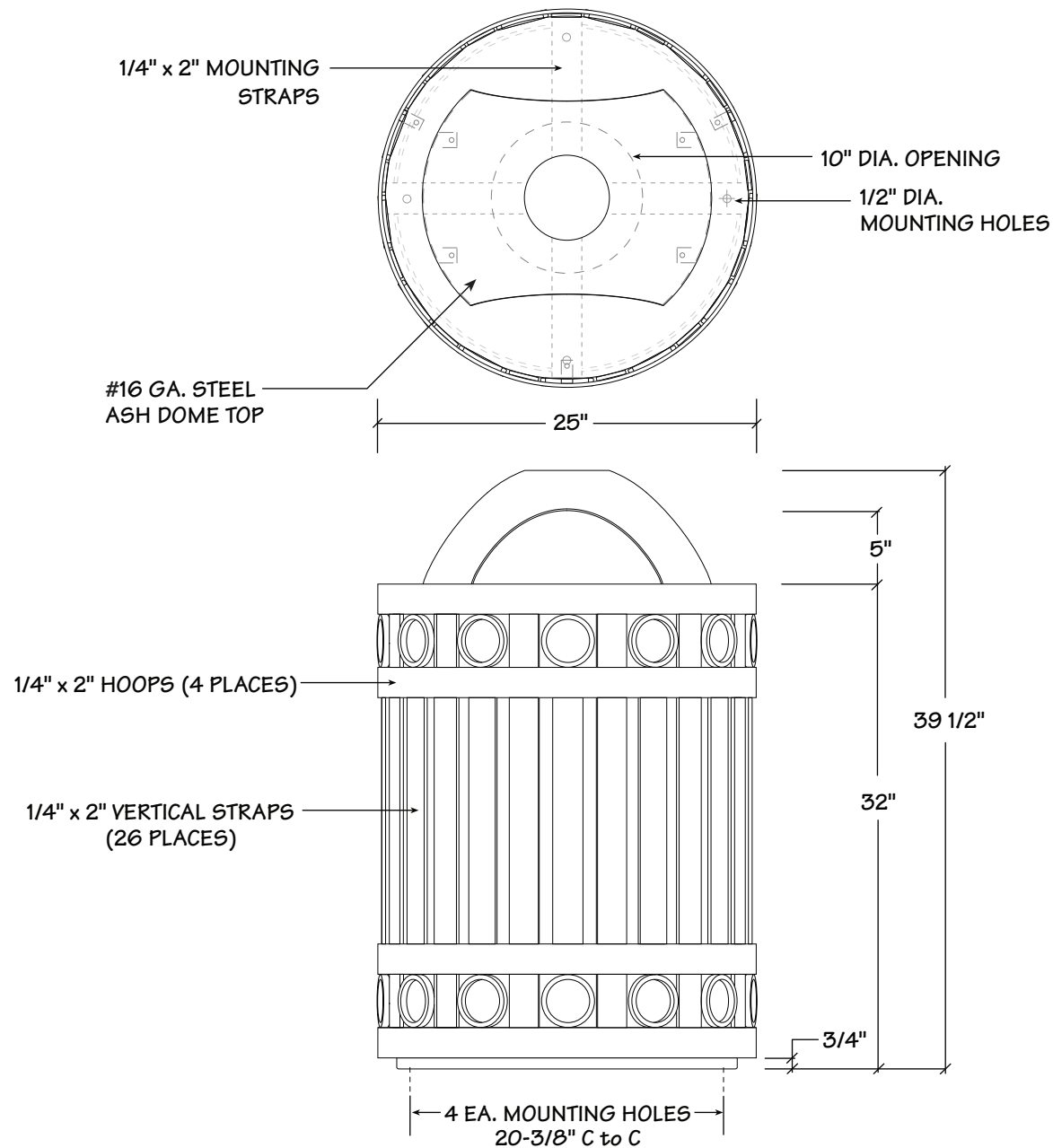

# TR-3 Trash Receptacle with Ash Dome Top

## FairWeather Site Furnishings

360-895-2626 or Toll Free 800-323-1798

Port Orchard, Washington

©1999-2004 Leader International Corporation.

FairWeather Site Furnishings division