

REV. 3-03-08

SPECIFICATIONS

MATERIAL

Wood: 19 each 1 1/2" x 1 3/8" lpe wood elements. All edges eased.

Seat Frame: 1 piece fully welded frame fabricated with 3/8" x 2 1/2" and 3/8" x 1" steel strap. All steel shall conform to ASTM A 36 hot rolled steel and shall be wheelabrated prior to fabrication.

End Frames: 1 1/4" thick ductile cast iron end frames.

Stretcher bar: 3/4" cold rolled steel rod.

FASTENERS

Wood shall be attached to seat frame with #14 stainless steel screws. Ductile cast iron end frames and steel stretcher bar shall be attached to seat frame with 1/2" x 2" pinned SS buttonhead bolts, 3/8" x 1 1/4" SS buttonhead bolts, 1/2" friction rings and powder coated 2 1/4" decorative washers.

Anchor bolts by others.

PROTECTIVE COATINGS

Wood: clear wood preservative

Metal: Following fabrication, all metal elements shall be cleaned and treated with an iron phosphate process prior to the coating application. This process shall include a non-chromated alkaline cleaner and an iron phosphate treatment followed with an acidic sealer for maximum adhesion. The protective coatings shall be either polyester or polyester TGIC powder. Following application the parts shall be baked until properly cured. The coating shall be a minimum of 4 mils thick on all surfaces.

OPTIONS

Length: 4 to 8 ft. standard, other lengths available

TD-4 bench lengths up to 8 ft available without an additional frame. All benches longer than 8ft. will require a center frame.

Tradition Series, Model TD-4 Bench

FairWeather Site Furnishings

360-895-2626 or Toll Free 800-323-1798

Port Orchard, Washington

©1999-2008 Leader International Corporation,
FairWeather Site Furnishings division

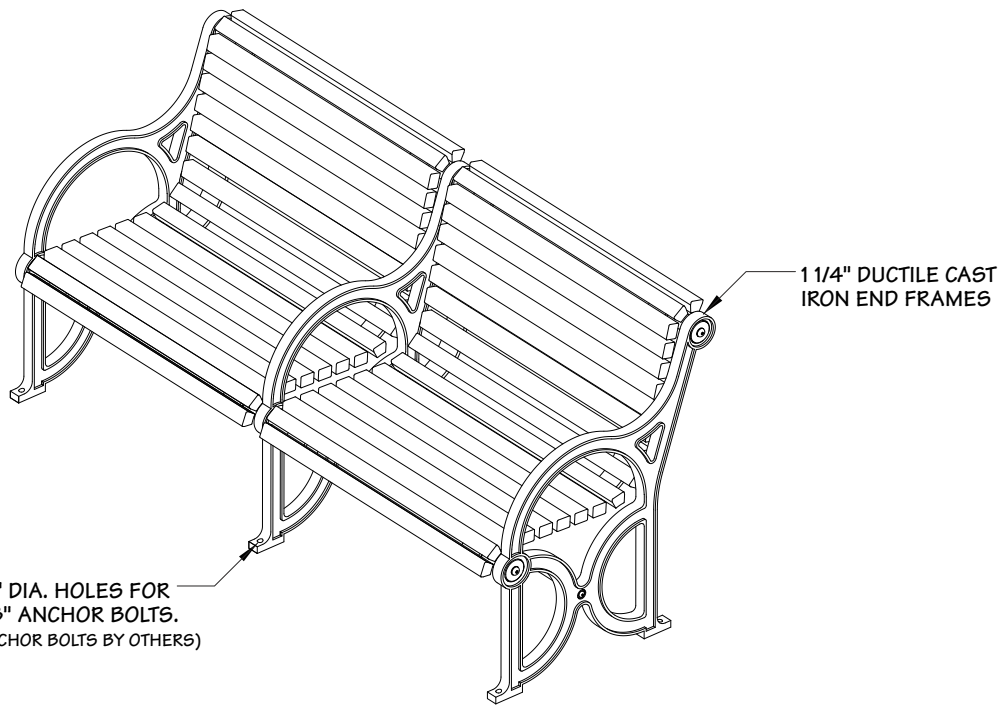

1/2" DIA. HOLES FOR
3/8" ANCHOR BOLTS.
(ANCHOR BOLTS BY OTHERS)

1 1/4" DUCTILE CAST
IRON END FRAMES

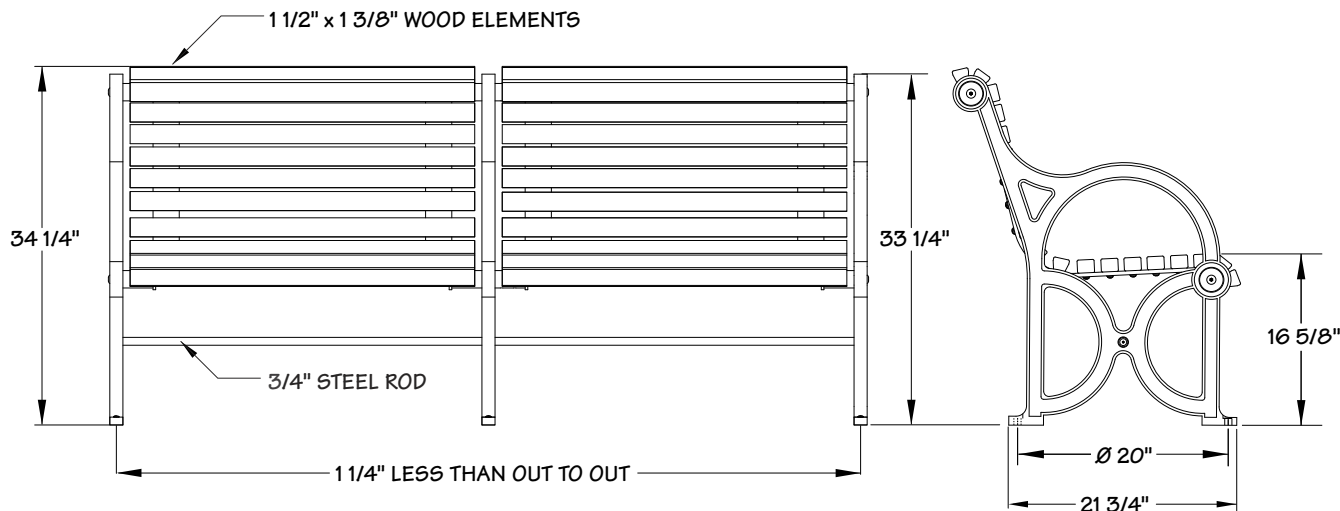

REV. 3-04-08

SPECIFICATIONS

MATERIAL

Wood: 19 each 1 1/2" x 1 3/8" lpe wood elements.
All edges eased.

Seat Frames: 1 piece fully welded frame fabricated with 3/8" x 2 1/2" and 3/8" x 1" steel strap. All steel shall conform to ASTM A 36 hot rolled steel and shall be wheelabrated prior to fabrication.

2 End Frames and 1 Center Frame: 1 1/4" thick ductile cast iron.

Stretcher bar: 3/4" cold rolled steel rod.

FASTENERS

Wood shall be attached to seat frame with #14 stainless steel screws. Ductile cast iron end frames and steel stretcher bar shall be attached to seat frame with 1/2" x 2" pinned SS buttonhead bolts, 3/8" x 1 1/4" SS buttonhead bolts, 1/2" friction rings and powder coated 2 1/4" decorative washers.

Anchor bolts by others.

PROTECTIVE COATINGS

Wood: clear wood preservative

Metal: Following fabrication, all metal elements shall be cleaned and treated with an iron phosphate process prior to the coating application. This process shall include a non-chromated alkaline cleaner and an iron phosphate treatment followed with an acidic sealer for maximum adhesion. The protective coatings shall be either polyester or polyester TGIC powder. Following application the parts shall be baked until properly cured. The coating shall be a minimum of 4 mils thick on all surfaces.

OPTIONS

Length: 4 to 8 ft. standard, other lengths available

TD-4 bench lengths up to 8 ft available without an additional frame. All benches longer than 8ft. will require a center frame.

Tradition Series, Model TD-4 Bench with Center Frame

FairWeather Site Furnishings

360-895-2626 or Toll Free 800-323-1798

Port Orchard, Washington

©1999-2008 Leader International Corporation,
FairWeather Site Furnishings division